

---

# LIFEVIEW<sup>®</sup> PDA II IP66 version

Monitoring System for Partial Discharge

---

Brochure

February 2019  
Rev 1

---

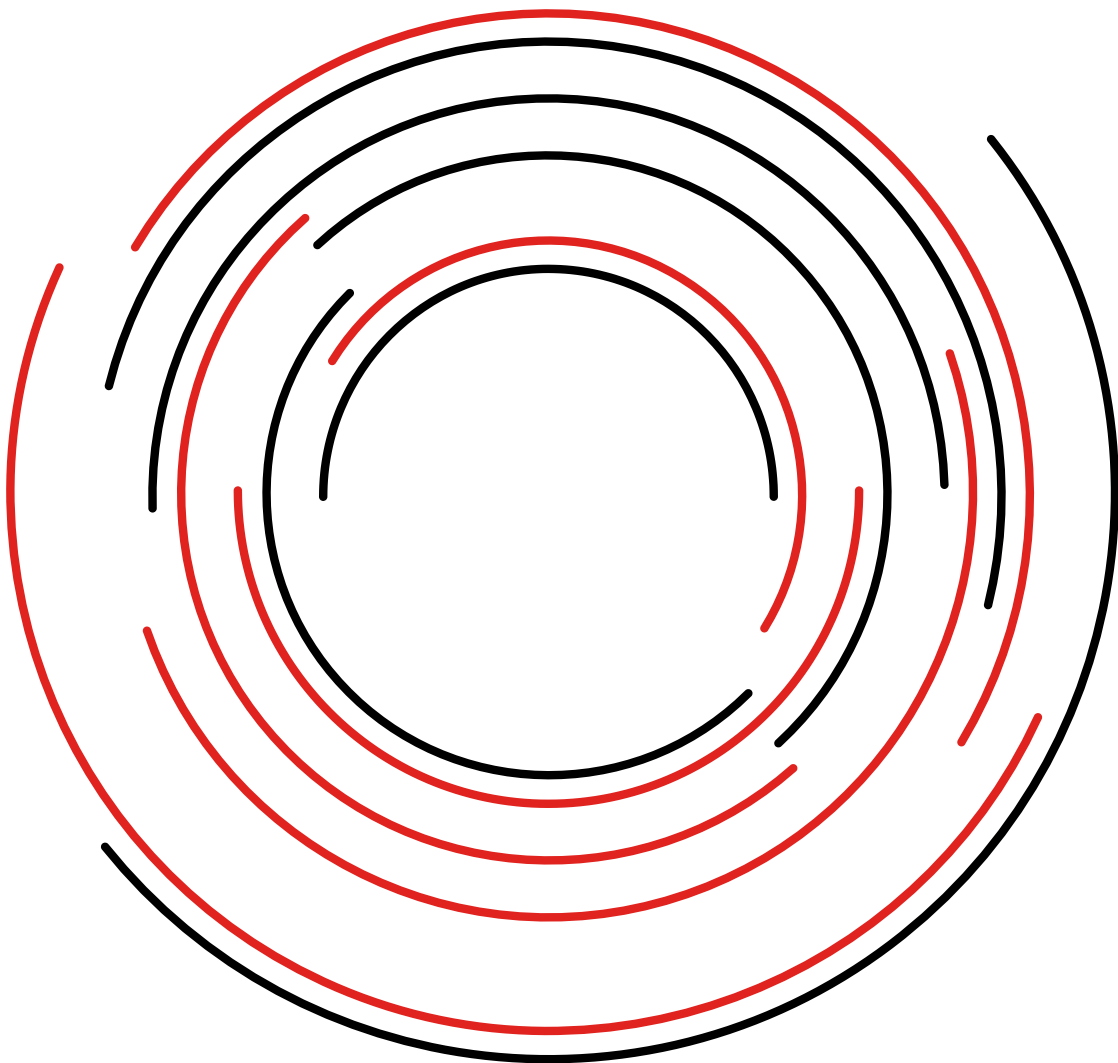

---

# 1 Summary

---

## Permanent installation for the continuous monitoring of your high voltage rotating assets

LIFEVIEW® PDA II is a permanent online condition monitoring system for high voltage rotating machines such as motors and generators. It provides a continuous monitoring of the Partial Discharge activity acting as a true watchdog warning the operator when the deviation is beyond the defined limits. The additional data provided by the system enables an expert to assess the insulation conditions of the machinery.

Designed to specifically monitor partial discharge, the LIFEVIEW PDA II is a cost effective solution which plays an important role within the overall site maintenance programme.

Unique features include:

- easy to understand data/results
- easy data download
- pre-set warning thresholds
- programmable filters
- analogue (4-20mA, relays) connections to the SCADA or DCS system



Figure 1: LIFEVIEW PDA II IP66

These unique features make the LIFEVIEW PDA II an ideal solution for operators looking for an effective, low-cost, user friendly PD monitoring without complex software.

The Partial Discharge measurements can be downloaded by customer/operator and sent to Quartztec Experts for detailed analysis.

Depending on the site requirements, the PDA II is available in two different versions:

- PDA II IP66 version for installation in safe area
- PDAII ATEX version for installation in hazardous area



Figure 2: LIFEVIEW PDA II ATEX

---

## 2 Features PDAII IP66 Version

---

- 24/7 permanent online monitoring
- Automatic periodic measurements
- Partial Discharge (PD) trending
- PD pattern graph (available with the advanced software version)
- Additional shaft voltage and air gap magnetic flux modules with trend
- Remote access via RJ45 Ethernet connection
- 2 x External USB ports
- 2 Alarm/Warning channels
- 4 x NO/NC relays and 4x Active 4-20mA outputs
- Stores up to 3 years of PD measurements including patterns (at 1 measurement per hour)
- Compatible with all Quartztec sensors as well as PD sensors from other manufacturers

---

## 3 Technical Specifications

---

### In-built Computer

Processor Intel Celeron N2807, 1.58GHz, low heat dissipation  
4GB RAM  
265GB SSD  
Windows 10 Professional

### Data Acquisition

Partial discharge	3 channels
Shaft voltage module	2 channels
Air gap Flux module	1 channel
A/D converter resolution	16 bits
Ad converter sampling rate	50kS/s
PD low cut-off frequency	100 kHz, 500 kHz, 1 MHz, 2 MHz
PD high cut-off frequency	1 MHz, 10 MHz

### Interfaces

Power supply	100-240VAC, 50-60Hz (Maximum power 60W)
Relay output	4 x NO/NC Channels
Analog output	4 x channels 4-20mA
Ethernet	2 x RJ45 (1 x External port)
USB	2 x External USB ports

### Software

Main display	PD Trends and warnings/alarms
Partial discharge trend	Qm
Output	Control of analogue & relay output
Partial discharge patterns	Y-axis in [pC] or [nC]
Shaft voltage module	Measured signal & FTT
Shaft voltage trend	Current & Voltage RMS value & max. value of the 10 firsts harmonics
Air Gap Magnetic Flux module	Normalised deviation

### Environment

Operating temperature	0 to 50 °C
Relative humidity	10% to 90%
Protection Degree	IP66 enclosure
Area classification	Safe area installation

### Mechanical specifications

Dimensions (LxWxD)	370mm x 330mm x 220mm (Without Cable Glands)
Weight (Approx.)	8 kg

## 3.1 Mechanical Specifications – IP66 Enclosure

Dimensions of the IP66 enclosure

- Length= 370mm
- Width= 330mm (without cable glands)
- Depth= 220mm

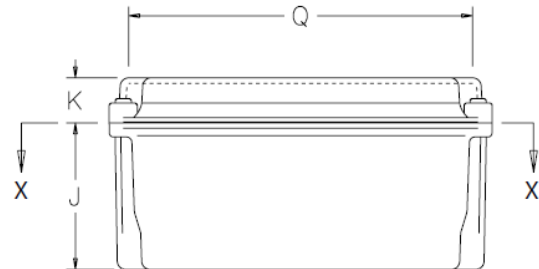
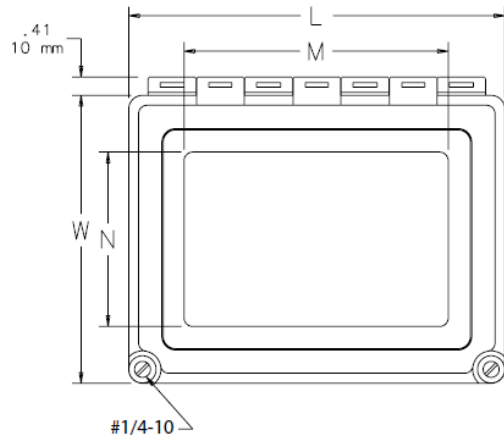

Mounting of the enclosure using connection plates

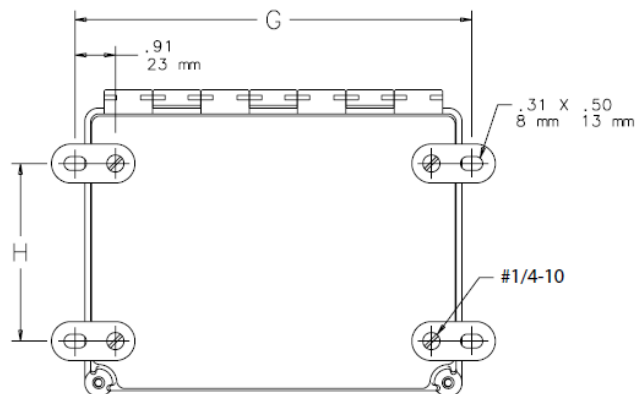

### Material supplied by Quartzteq

Following material is supplied with a PDAII IP66 kit:

- IP66 Enclosure with cable glands
- 4 x 8x50mm fixation screws
- 4 x 10mm wall plugs

## 4 Installation Overview

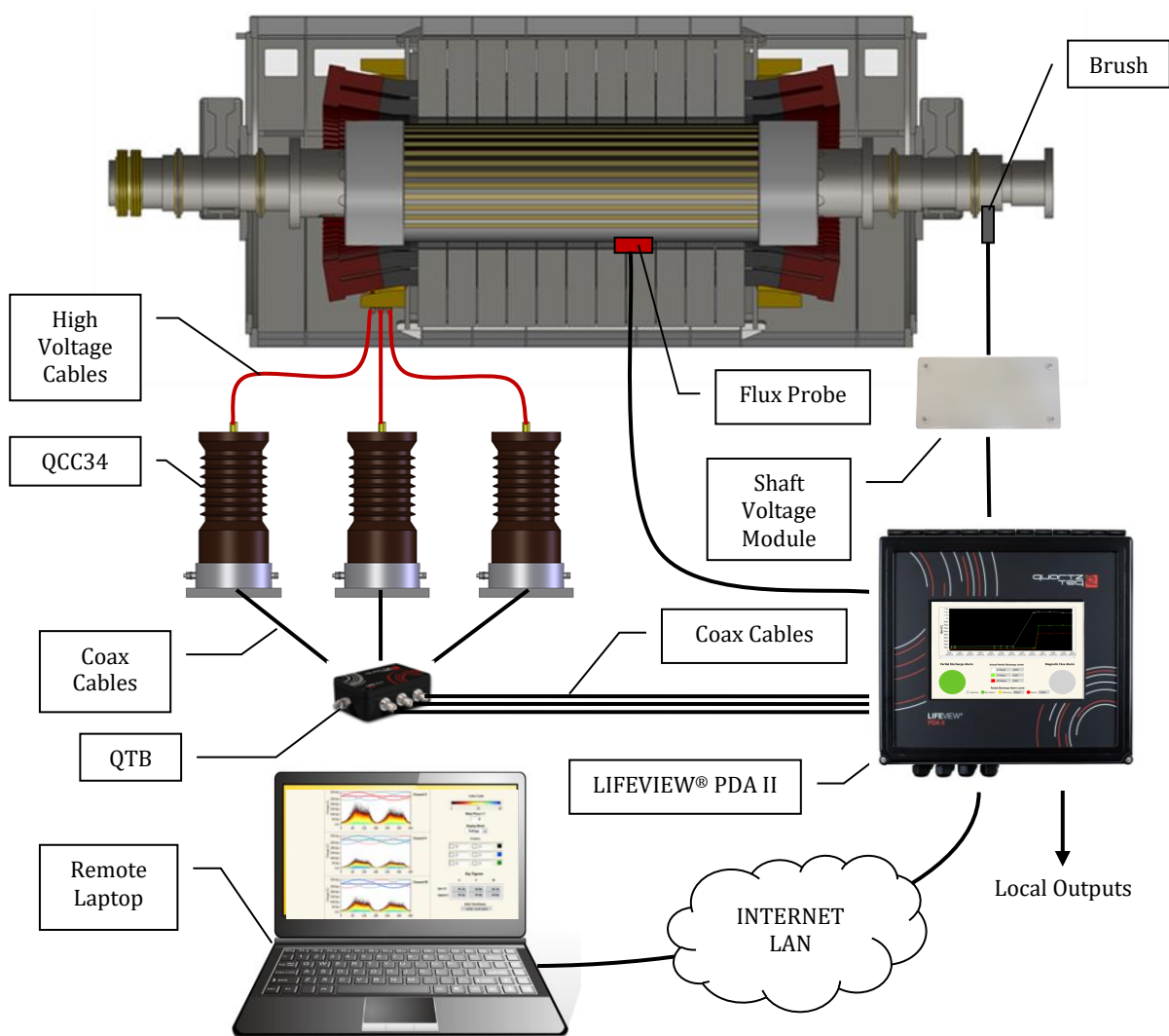

Figure 3: General layout of PDAII installation

- Partial Discharge sensors must be installed on each phase of the machine. They can be coupling capacitors or current transformers. LIFEVIEW<sup>®</sup> PDA II is compatible with most of third party's sensors.
- The sensors must be connected to a termination box (QT B) to protect users and the device against any failure of a coupler and provide good grounding.
- The termination box must be connected to the LIFEVIEW<sup>®</sup> PDA II device via coaxial cables RG58-CU 50Ω.
- Brushes must be installed on the machine's shaft in order to measure shaft voltage. A Grounding module must be connected between the brushes and the LIFEVIEW<sup>®</sup> PDA II device.
- A Flux probe must be installed in the stator of the machine, in the air gap, in order to monitor the air gap magnetic flux.
- Local outputs, such as relays and 4-20mA, can be connected to the control system of the site.

A LAN connection must be accessible by the LIFEVIEW<sup>®</sup> PDA II device to allow any user of any computer connected to the same network (or to internet) to access the system remotely.

## 5 Software

### Acquisition software

The pre-installed acquisition software on the LIFEVIEW® PDA II is called LIFEVIEW® Q4000 PDA II

Its main purpose is:

- Displaying PD trend graphs, warnings and alarms
- Taking manual and automated measurements and saving historical data
- Displaying last measurement details like PD patterns
- Configuration and calibration of the device

The Acquisition Software is available in two version: “Entry level SW” and “Advanced SW”.

With the Advanced SW version, the monitoring system will record both PD trends and PD patterns. This shall provide access to all historical PD trends as well as to all historical PD patterns.

Main features of these software versions are summarised in the table below.

Features	Entry level SW Version “PDAII_Light”	Advanced SW version
GUI (Main Display)	- PD Qm Trend and Warnings/Alarms	- PD Qm Trend and Warnings/Alarms
GUI (Extended Display)	- PD Qm and Qapp Trends - Warnings/Alarms - Partial Discharge Patterns	- PD Qm and Qapp Trends - Warnings/Alarms - Partial Discharge Patterns - Shaft voltage - Air Gap Magnetic Flux
Partial Discharge Trends (Qm, Qapp)	- online monitoring (fully configurable automatic periodic measurement)	- online monitoring (fully configurable automatic periodic measurement)
Partial Discharge Patterns (scatter graph)	- manual measurements	- manual measurements - automated measurements - saving of all historical PD patterns

### Viewer software

There is a second software available which can be installed on any computer for data analysis. It is called LIFEVIEW® Q4000 Viewer.

Its purpose is:

- Accessing saved historical measurements and showing details like PD patterns
- Displaying trend graphs
- Verifying data by changing parameter like phase shift and measurement modes

The acquisition software should be used by an expert during the installation in order to configure the device correctly, according to the machine specifications.

The viewer software should be used by an expert to see the measurement details and assess the state of the machine.

## 5.1 Start-up Screen

When the software is started, the first screen shows the historical trend of the PD-values  $Q_m$  as well as actual PD levels of the three phases (last measurement).

Additionally two lights are shown. They represent the two possible warning and alarm values, which can be configured in the settings menu.

Lights will change their colour as follows:

- Green: Everything ok
- Yellow: Warning (first, lower defined level)
- Red: Alarm (second, higher defined level)
- Grey: Inactive

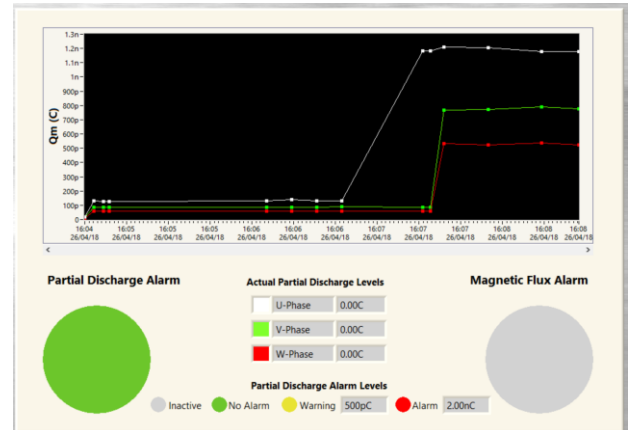

Figure 4: PDAII main screen PD Trend and Alarms

## 5.2 PD Overview

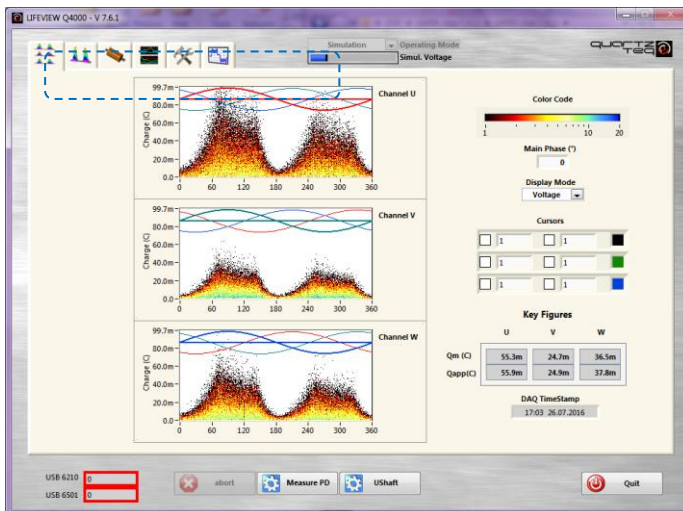

Figure 5: PD overview

- Selection tabs  
Navigation to the different parts of the software
- Operating mode  
DAQ: Acquisition mode (records real measurements)  
Simulation: Simulates machine signals to test the software
- Main Phase  
Phase shift in degrees for the PD Patterns
- Display Mode  
See figure below
- Cursors  
Cursors can be displayed on the patterns
- PD Level  
Qm: largest repeatedly occurring PD magnitude: IEC60034-27  
Qapp: apparent charge: IEC6027

## Display Mode

Two different display mode are available.

## Voltage Mode

The phase reference is calculated separately for each phase. The PD Pattern is displayed relatively to the phase angle of each phase. This mode shows directly the PD Pattern for the corresponding phase according to its angle. It can be used to see the PD activity of a phase, according to the voltage of this phase.

## Time Mode

A common reference phase is used for the three phases. This mode is useful to see cross-talk in the PD signals between the phases or to identify disturbances on the signal.

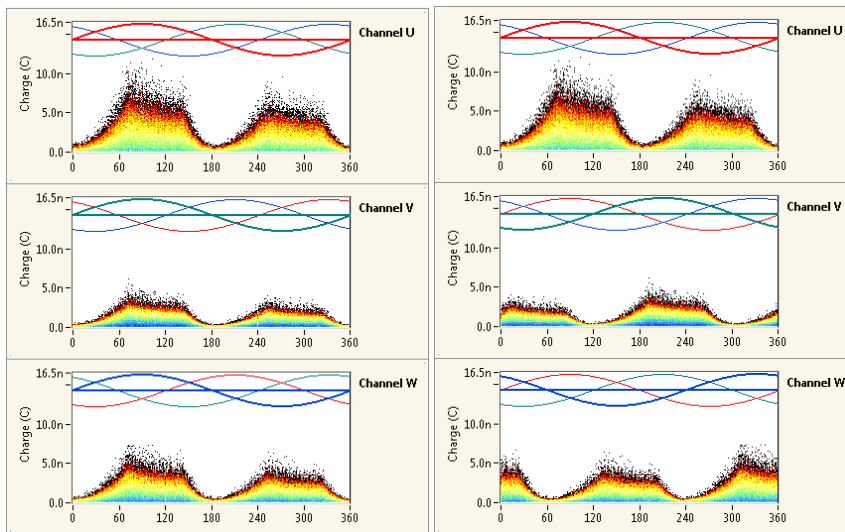

Figure 6: Voltage mode and Time mode

## 5.3 Trending

This figure shows the "Trend" tab of the software, history of the partial discharges and shaft voltage values.

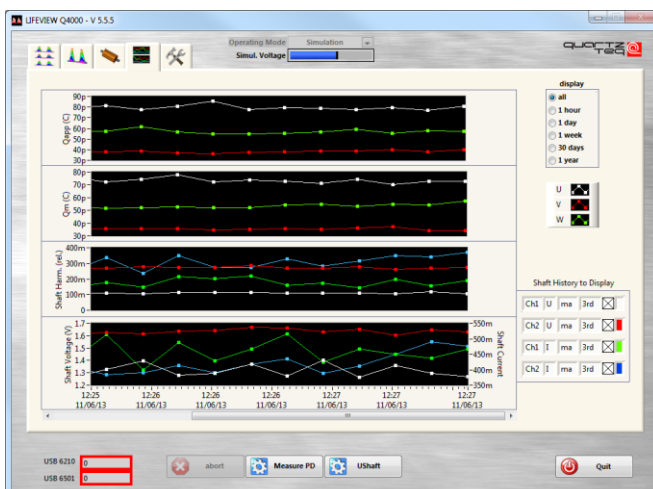

Figure 7: Trend display



## 5.4 Shaft Voltage

This figure shows the optional shaft voltage module of the LIFEVIEW® Q4000 PDA II software.

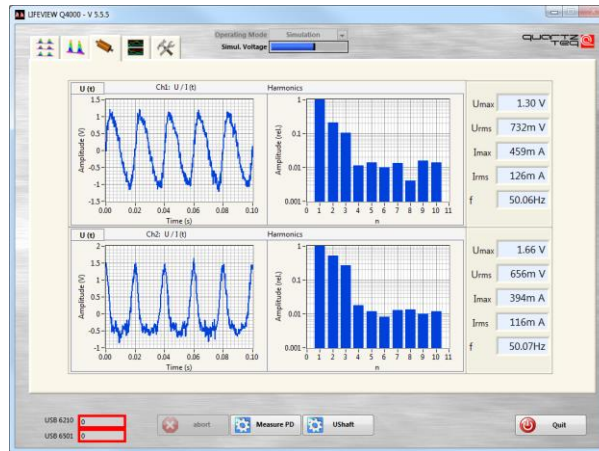

Figure 8: Shaft voltage display

The left part shows the measured signal of both shaft voltage sensors. The right part shows the corresponding frequency spectrum. On the right hand side of the screen information on the signals are displayed.

## 5.5 Air Gap Magnetic Flux

This figure shows the optional Air Gap magnetic Flux tab of the software.



Figure 9: Air Gap Magnetic Flux display

### Top Graph

The top graph displays four curves:

- Blue Flux Integral of the measured air gap flux. It corresponds to the total flux
- Red Flux Probe Signal coming from the flux probe and measured by the software
- Green FP shifted Corresponds to the red signal, inverted and shifted of one half period
- Purple Diff Difference between the red and the green signal

### Bottom Graph

The normalised signal corresponds to the purple signal of the top graph, normalized with the flux amplitude.